



Laval (Greater Montreal)

June 12 - 15, 2019

NUMERICAL INVESTIGATION OF THE LATERAL RESPONSE OF SINGLE AND DOUBLE CONTROLLED ROCKING STEEL BRIDGE PIERS

Rahmzadeh, A.^{1,5} Hossain, F¹. Islam, K². Alam, MS³. Tremblay, R⁴.

¹ PhD Student, ³ Associate Professor, School of Engineering, The University of British Columbia, Kelowna, BC, Canada.

² PhD Student, ⁴ Professor, Department of Civil, Geological and Mining Engineering, Polytechnique Montreal, Montreal, QC, Canada.

⁵ a.rahmzadeh@ubc.ca

Abstract: This paper presents a numerical investigation on the lateral behavior of controlled rocking steel bridge piers. The rocking behavior limits plastic straining in the column as the main cause of damage in the conventional counterparts. To achieve a positive post-uplifting stiffness, the pier is pre-stressed by a post-tensioned (PT) tendon. The system exhibits a self-centering property, unless severe local buckling occurs near the rocking interface. The lateral response of the system with various diameter-over-thickness ratios is explored using continuum finite element (FE) method. Base and double rocking configurations are considered. The double rocking configuration surpasses the base rocking in the stiffness, lateral load capacity and energy dissipation, however, exerts more demand on the tendon which might result in its failure. A macro model with two springs at extreme fibers of the column is developed and used to study the effect of modeling approach in the load-displacement behavior. It is shown that the simplified uplifting mechanism used in the macro model leads to an overestimation of the lateral load capacity and pre and post uplifting stiffnesses of the system.

1 INTRODUCTION

The occurrence of the 1994 Northridge and 1995 Kobe earthquakes was a pivotal point in structural engineering. Before these earthquakes, it was imagined that structural engineering had served its goal by saving people's lives. However, tremendous economic losses due to severe damages to code-designed structures during the aforementioned earthquakes (Eguchi et al. 1998, Horwich 2000) showed that a detailed procedure rather than a simplified prescriptive approach should be developed for controlling the damage. In striving for this goal, seismic codes adopted capacity design principles in which provisions are set to restrict inelastic deformations to deformation-controlled components, capable of high deformation capacity, and design force-controlled components with adequate strength to remain elastic. Nevertheless, the occurrence of the plastic hinge in the deformation-controlled components under moderate earthquakes or in both deformation and force-controlled components under severe earthquakes results in permanent residual drift and may require complete replacement of the structure. This was highlighted by suffering a loss of over NZ \$20 billion during the 2011 Christchurch earthquake (Elwood 2013).

Piers in a bridge, as front liners in resisting seismic forces, are susceptible to damage during an earthquake. Since it is not economical nor practical to design a pier to remain completely elastic and damage-free in an earthquake, conventional seismic codes prescribe the use of inelastic capacity of steel. However, past earthquakes have shown that bridge piers designed based on the conventional seismic codes experience destructive damages which result in crippling bridge serviceability.

There has been a growing interest in the controlled rocking systems which are capable of swinging along the earthquake and reverting to their original position afterwards. This paper is an extension to a previous study in which a controlled rocking steel bridge pier was proposed and numerically and analytically investigated (Rahmzadeh, Alam, and Tremblay 2018). The pier consists of a tubular steel column, a post-tensioned tendon, and supplemental energy-dissipative elements. Gap opening and closing, as a result of the rocking mechanism at the connection interface, provides substantial deformation capacity under lateral loading. When combined with supplemental energy dissipating elements, a hybrid system with a characteristic flag-shaped hysteresis behavior is obtained (Figure 1). In this paper, the cyclic lateral response of the system with various diameter-over-thickness ratios is explored using continuum finite element (FE) method. Base and double rocking configurations are considered. Moreover, a macro model with two springs at extreme fibers of the column is developed and used to study the effect of modeling approach in predicting the seismic response.

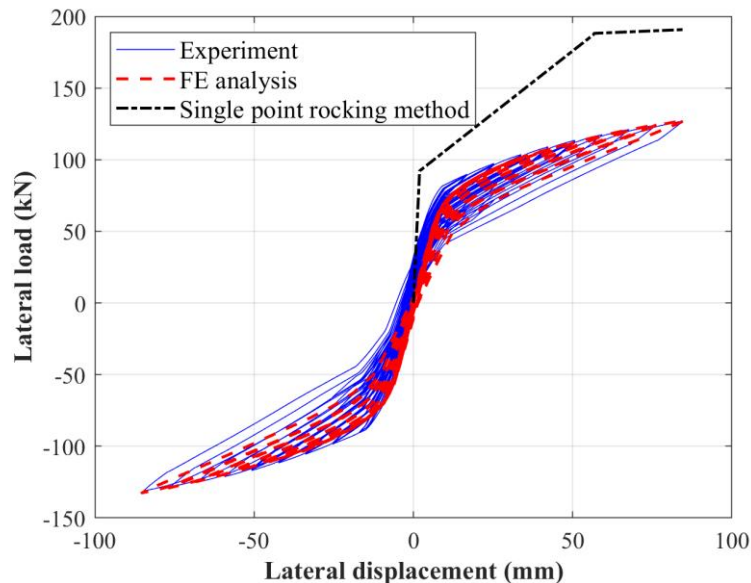

Figure 1. Cyclic response of a single rocking steel bridge pier.

2 DESCRIPTION OF BENCHMARK BRIDGE

The details of the studied bridge are shown in Figure 2. It is a major bridge with two 33 m long spans located in Vancouver, BC. The pier consists of a hollow circular column, 15 high-strength seven-wire strands posttensioned up to 30% of their ultimate strength, and end plate(s). The height of the pier from the base to the centroid of the superstructure is 6900 mm. The calculated weight of the superstructure is 122 kN/m which results in a dead load of 5033 kN and a seismic weight of 8052 kN. Buckling-restrained energy dissipaters were evenly placed around the tube at the rocking interface(s). The energy dissipater comprises of a steel bar, fused down to a diameter of 20 mm, confined within a steel tube and epoxy as the gap filler.

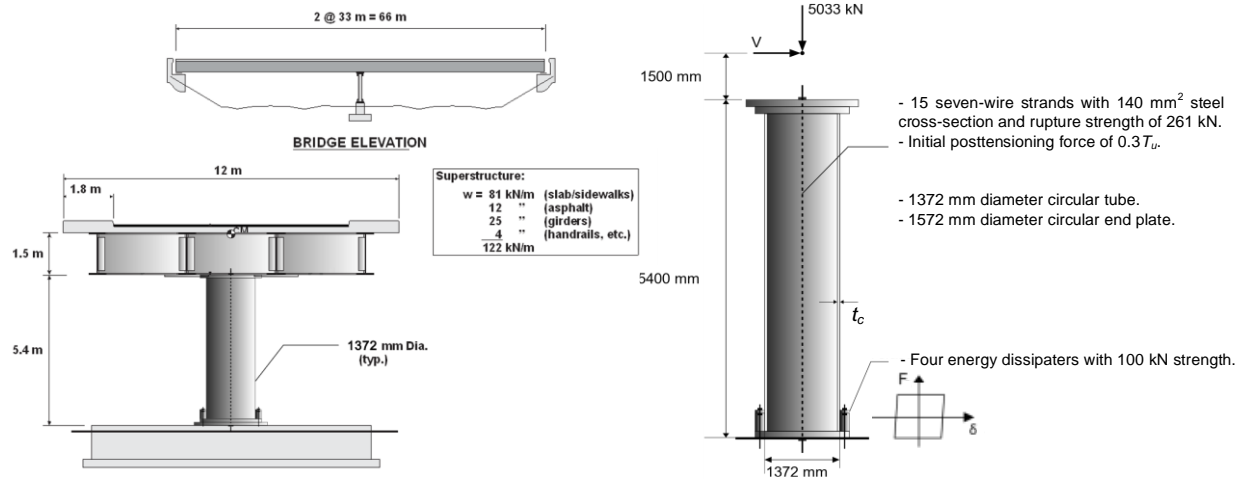

Figure 2. Details of the considered bridge.

3 FE CYCLIC ANALYSIS

3.1 Single rocking configuration

The components of the FE model are illustrated in Figure 2. Detailed description of the FE modeling procedure of such piers can be found in Rahmzadeh et al. (2018). All components are modeled using solid elements except the energy dissipaters that are simulated by macro elements (ANSYS 2017). Doing so reduces the number of elements significantly and leads to much less computational time. The loading protocol consists of three cycles of lateral drift with an amplitude of 0.5, 1, 1.5, 2, 2.5 and 3% followed by two cycles of 3.5, 4, 4.5 and 5% lateral drifts.

Two diameter-over-thickness ratios (42 and 86) were considered to investigate the effect of local buckling. The development of a permanent bulge near the rocking interface increased the energy dissipation as can be seen in Figure 4(a), however, the re-centering property remained intact as local buckling did not significantly progress. To study the effect of end plate, two specimens with thicknesses of 25 and 75 mm were analyzed. As shown in Figure 4(b), the specimen with thicker end plate has higher post-uplifting stiffness due to less flexibility of the rocking interface.

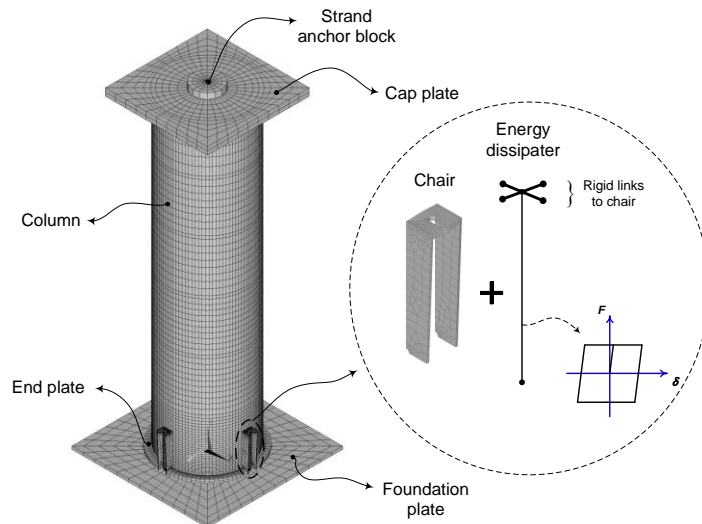

Figure 3. Developed FE model components.

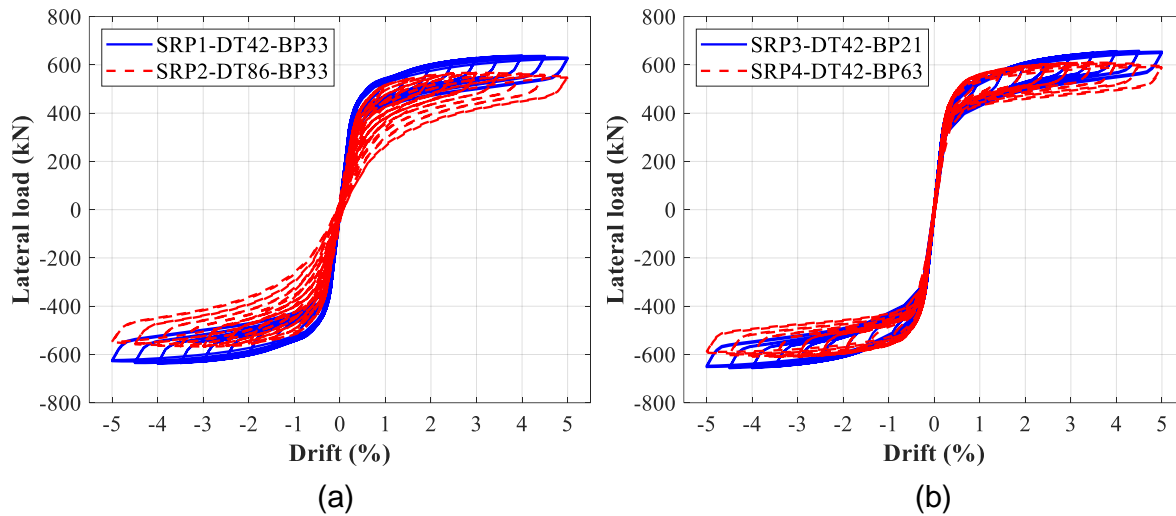

Figure 4. Lateral cyclic response of the specimens with: (a) various wall thicknesses and (b) various end plate thicknesses.

3.2 Double rocking configuration

The previous specimens were transformed to double rocking configuration by constraining the rotational degree of freedom of the cap plate which allows the formation of another gap at the top. Hence, the main assumption herein is that the superstructure remains horizontal during the lateral deformation of the pier. The comparison between the two configurations is shown in Figure 5. The pre and post-uplifting stiffnesses and lateral load capacity improved by the virtue of the double curvature deformation of the column. However, the tendon started yielding in the midway of lateral cycling and failed at 5% drift, resulting in asymmetry in the response. Although the tendon failed, the system re-centered due to presence of the superstructure weight.

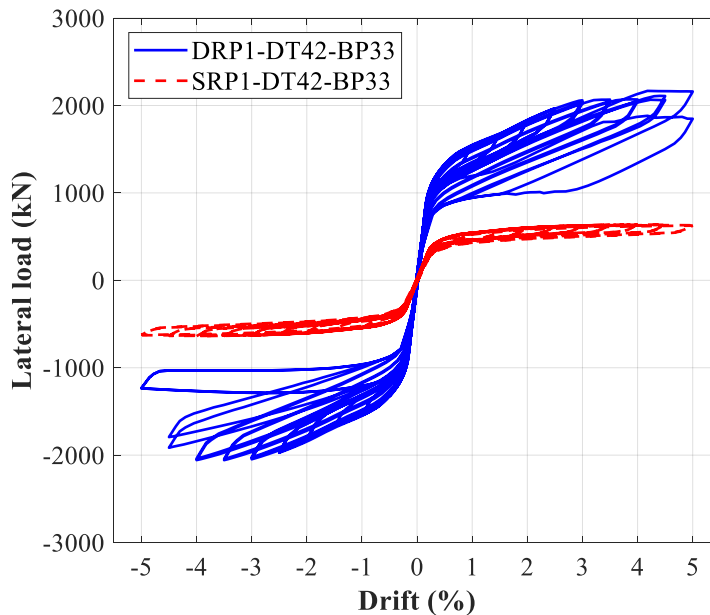

Figure 5. Load-displacement response of double and single rocking configurations.

The effect of diameter-over-thickness ratio of the column and end plate thickness was investigated for such a configuration as shown in Figure 6. The evolution of the bulge near the rocking interfaces resulted in the shortening of the column and following that less strain demand on the tendon. Hence, the tendon in the specimen with the thinner wall did not fail, yet, yielded (Figure 6a). The thickening of the end plates, increased the lever arm of the tendon force and as a consequence, the tendon failed earlier (Figure 6b).

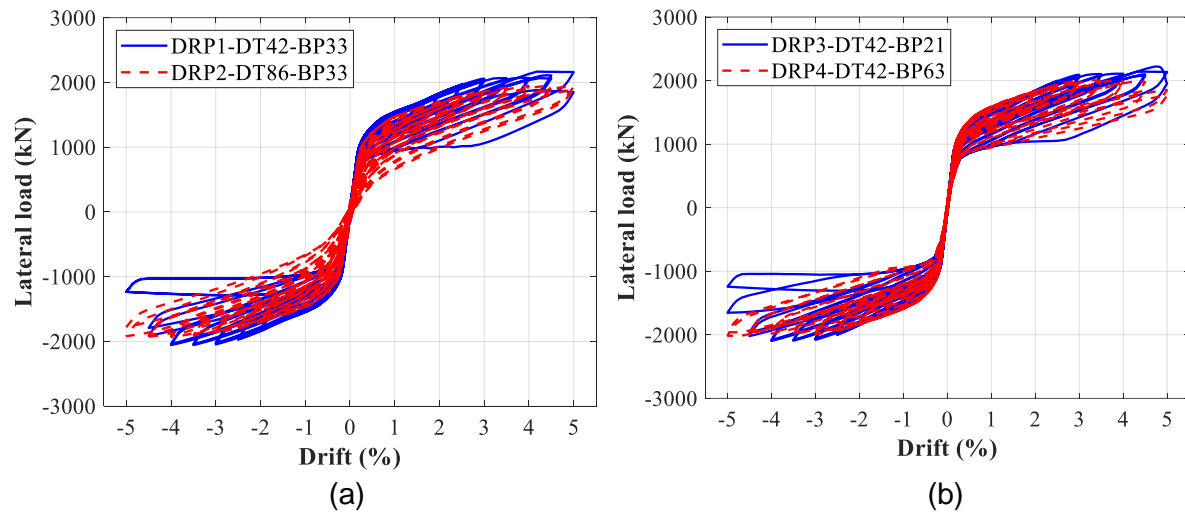

Figure 6. Lateral cyclic response of the specimens with: (a) various wall thicknesses, and (b) various end plate thicknesses.

4 FE SEISMIC ANALYSIS

4.1 Description of simplified macro model

Figure 7.a demonstrates the details of the two-dimensional macro model for the single rocking pier. The column and cable are modeled with a linear beam element connected to a node at the top, and different nodes at the bottom. A rigid link was employed to simulate the base plate as well as the distance between the top of the column and the centroid of the superstructure. Springs with nonlinear elastic-perfectly plastic behavior were used to model the energy dissipaters. In order to simulate gap opening/closing, gap elements with infinite stiffness in compression and zero stiffness in tension were placed at the edges of the base plate and fixed at the base (Tremblay et al. 2019).

Although it is practical and computationally efficient, the macro model is unable to capture the initial stiffness, transition between decompression and uplifting, and lateral load capacity properly as opposed to the continuum model (Figure 1). This is due to the fact that in reality the uplifting phenomenon is gradual because of the flexibility of the rocking interface, whereas in the macro model it is assumed that the column suddenly pivots around its edge. The comparison between the cyclic response of the 3D continuum and 2D macro FE models is shown in Figure 7.b for specimen SRP1-DT42-BP33. The aim of the following section is to investigate the difference in the seismic response prediction of the rocking pier that is arisen by utilizing a simplified modeling approach.

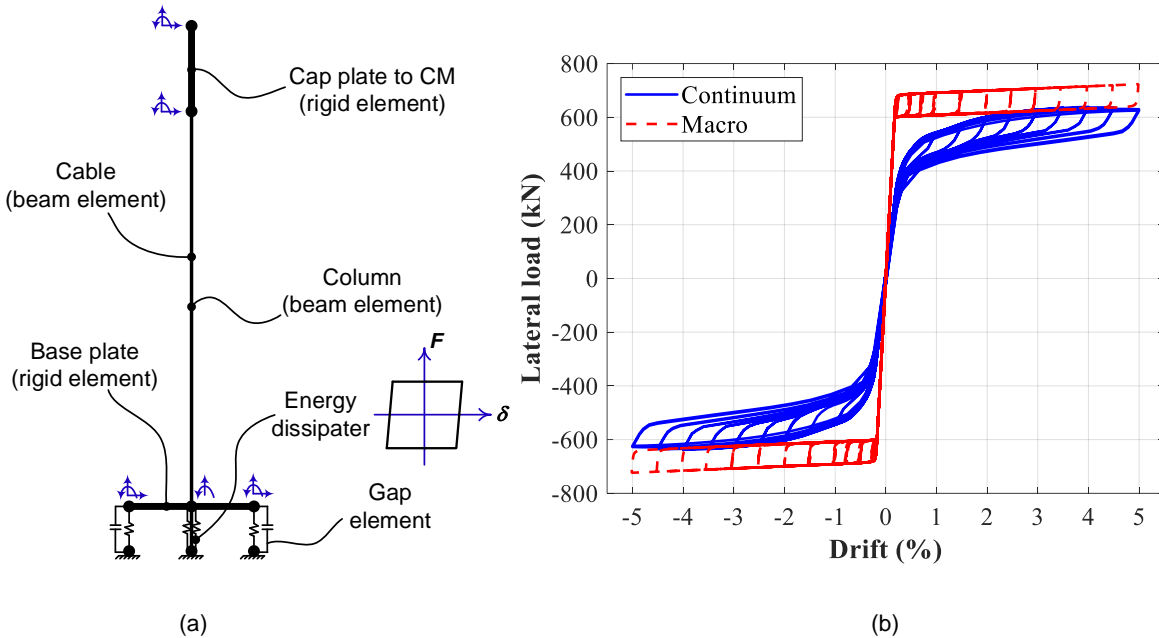

Figure 7. (a) Details of single rocking pier macro model, (b) Cyclic response based on continuum and macro models.

4.2 Nonlinear time history analysis

Four ground motion records were selected and scaled to match the CSA S6-14 (CHBDC 2014) design spectrum for site class C. The details of each earthquake record are given in Table 1.

Table 1. Earthquake records.

ID	Event	Year	Station	Magnitude	R (km)	Component
V306	Northridge	1994	Castaic Old Ridge Route	6.7	21	90 deg.
V307	Northridge	1994	Brentwood VA Hospital	6.7	23	195 deg.
V308	Northridge	1994	Sunland Mt Gleason Ave	6.7	13	170 deg.
V311	Kern County	1952	Lincoln School	7.4	46	21 deg.

In the macro model, the ground acceleration was applied directly while in the continuum model the acceleration record was integrated twice and the corresponding displacement was imposed to the base. In both modeling approaches, Rayleigh damping corresponding to 3% of critical in the first and third modes was assigned. In order to prevent the erroneous damping forces, the stiffness proportional damping was only assigned to the material of the column. The dead load and seismic weight were defined as vertical and horizontal masses, respectively. Prior to performing time history analysis, static pre-stressing and gravity loading were conducted. The analyses were conducted for specimen SRP1-DT42-BP33.

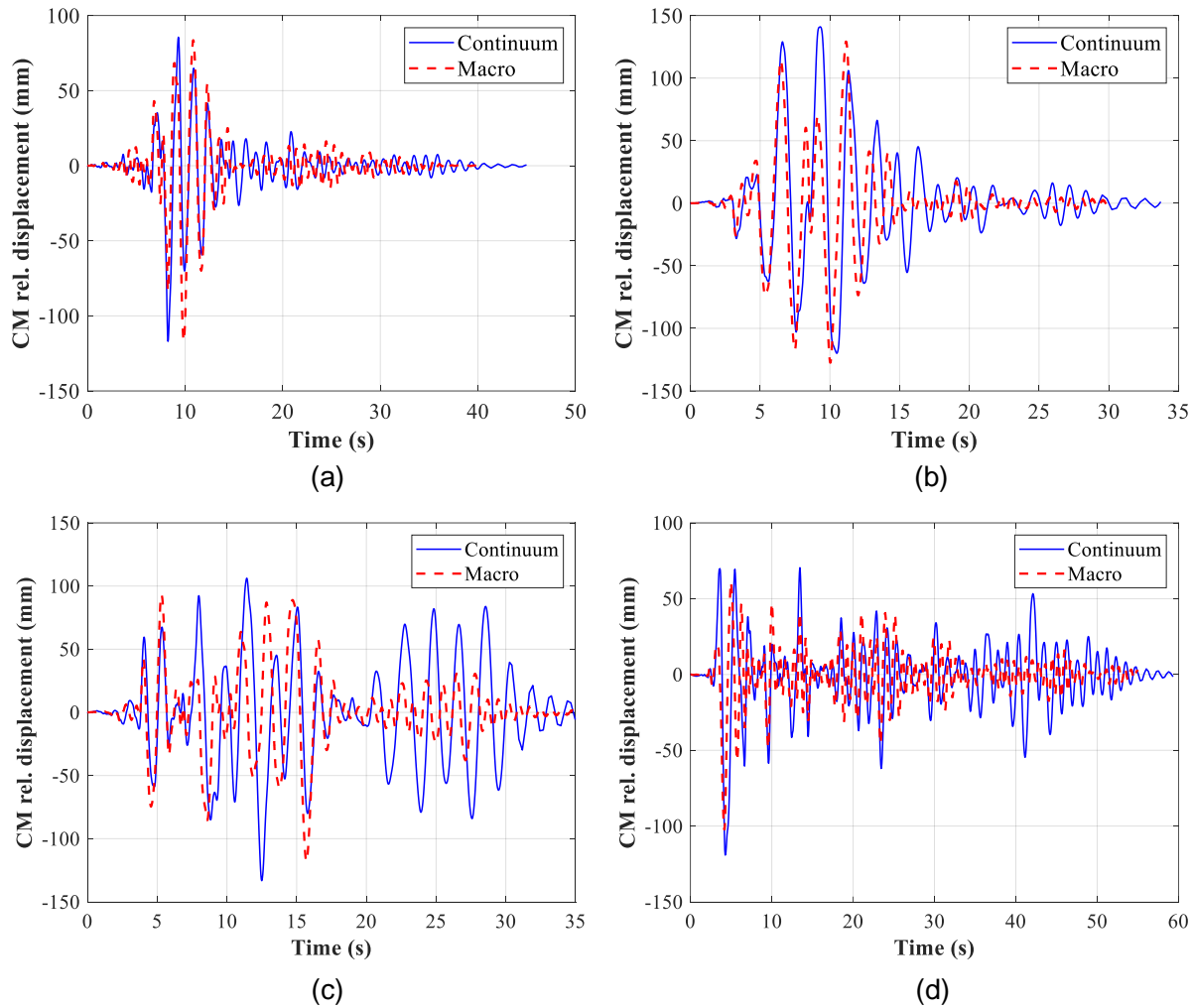

Figure 8. Displacement of CM relative to the base for (a) record V306, (b) record V307, (c) record V308, and (d) record V311.

The displacement of the superstructure centroid under the considered records is shown in Figure 8. As expected, the displacement demand in the continuum model is higher than that of the macro model due to the difference in the stiffness and lateral load capacity. Effects of vertical impact are more pronounced in the macro-model due to the sharp increase in stiffness when the column returns to its original condition after rocking (Figure 9). In the FE model, the column exhibits a smooth transition between the two conditions due to the bending of the base plate. The lateral resistance of the rocking model is overestimated by the macro-model as the model assumes a fixed position for the rocking point. The FE model shows that the pivot point in fact progressively migrates towards the center of the column due to localized yielding of the base plate in flexure, which reduces the level arm of the compressive force resultant (Figure 10).

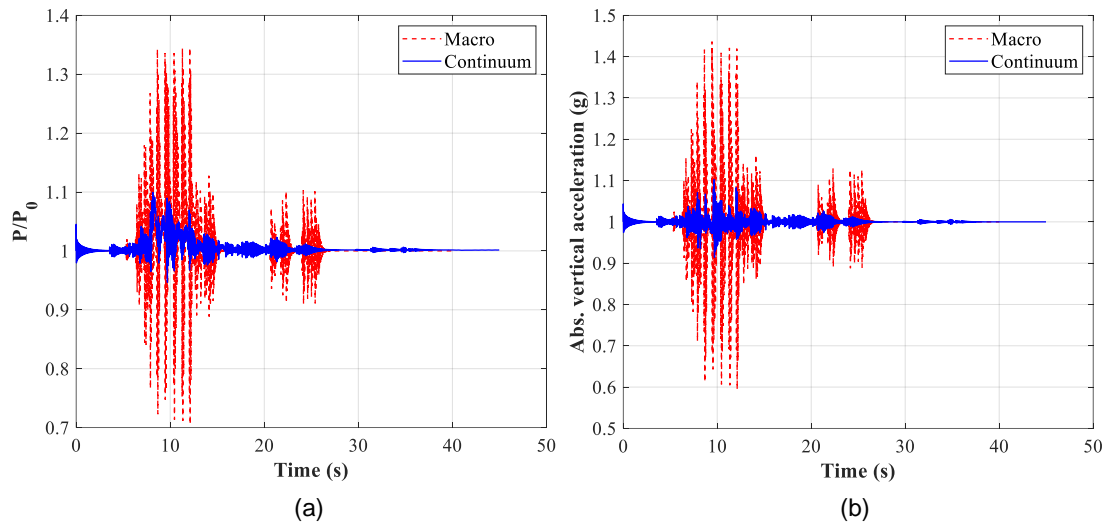

Figure 9. (a) Column axial force ratio, (b) Vertical acceleration for V306.

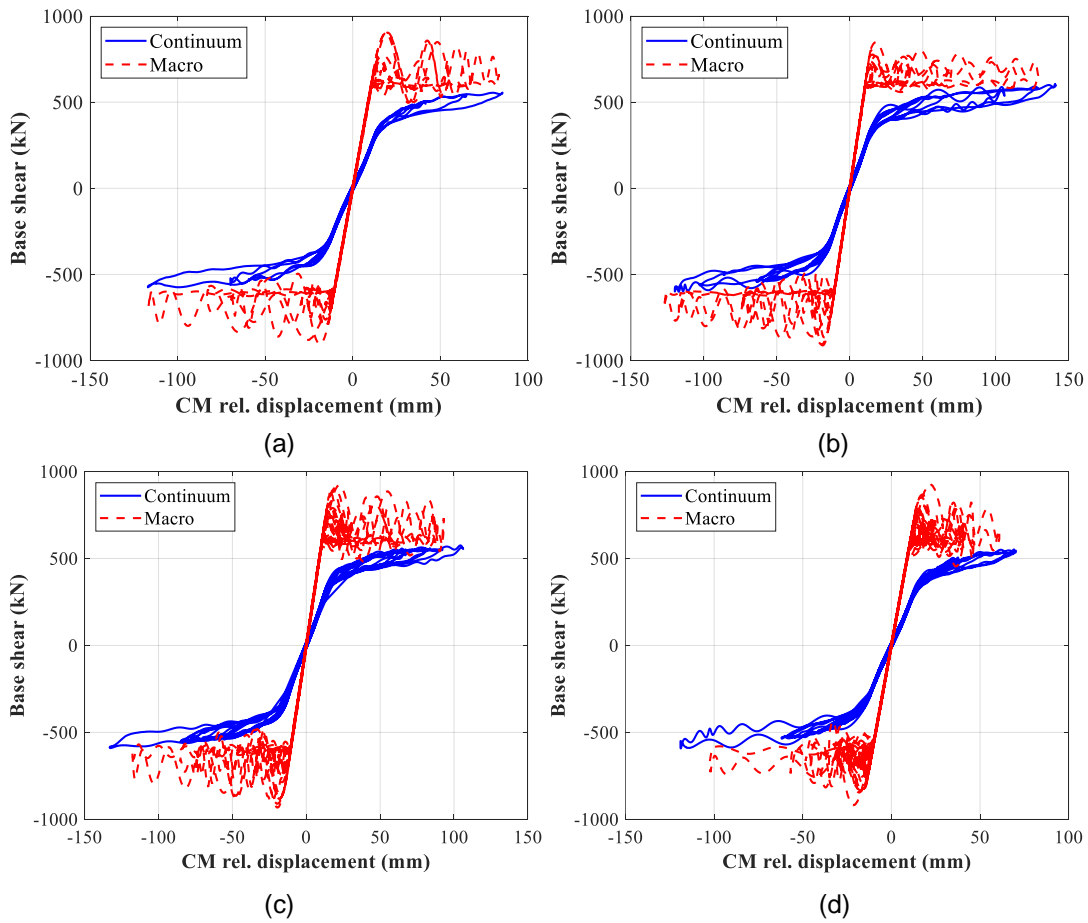

Figure 10. Load-displacement response under for (a) record V306, (b) record V307, (c) record V308, and (d) record V311.

5 CONCLUSIONS

Single and double controlled rocking steel bridge piers have been numerically investigated. The motion of the pier is limited to uplifting by the use of a PT tendon. Cyclic analyses were performed to study the effect of diameter-over-thickness ratio of the tube and end plate thickness. It was shown that for a moderately thin tube wall the energy dissipation increases due to bulging of the tube near the rocking interface which is not desirable. The base plate thickness does not affect the re-centering property, however, it influences the post-uplifting stiffness by changing the lever arm of the compressive force resultant at the rocking interface. By using a double rocking configuration, the lateral performance of the pier can be significantly enhanced. However, the tendon should be designed accordingly as the strain demand is almost twice in this case. A simple practical 2D macro model was developed to predict the lateral response of the single rocking pier. It was demonstrated that such a simple model overestimates the stiffness and lateral load capacity of the system compared to the 3D continuum model. These differences lead to a different seismic response which cannot be neglected. However, the macro-model could still reasonably predict peak lateral displacements and therefore could be used for this purpose in design.

6 ACKNOWLEDGEMENTS

The research reported herein was funded by Natural Sciences and Engineering Research Council of Canada (NSERC) under Collaborative Research and Development (CRD) grant, and several industrial partners including Canadian Institute of Steel Construction, Rapid Span Structures Ltd, S-FRAME Software Inc, Emil Anderson Construction Inc, Klohn Crippen Berger Ltd. The authors would like to acknowledge CMC Microsystems for the provision of products and services that facilitated this research, including ANSYS Multiphysics. The support provided by Compute Canada is also gratefully acknowledged.

7 REFERENCES

- ANSYS Multiphysics v18.2. ANSYS Inc., Canonsburg, PA.
- CHBDC. 2014. Canadian Highway Bridge Design Code. CSA Group.
- Eguchi, Ronald T, James D Goltz, Craig E Taylor, Stephanie E Chang, Paul J Flores, Laurie A Johnson, Hope A Seligson, and Neil C Blais. 1998. "Direct Economic Losses in the Northridge Earthquake: A Three-Year Post-Event Perspective." *Earthquake Spectra*. doi: 10.1193/1.1585998.
- Elwood, Kenneth J. 2013. "Performance of concrete buildings in the 22 February 2011 Christchurch earthquake and implications for Canadian codes." *Canadian Journal of Civil Engineering* 40 (8):759-776. doi: 10.1139/cjce-2011-0564.
- Horwich, G. 2000. "Economic Lessons of the Kobe Earthquake." *Economic Development and Cultural Change* 48 (3):521-542. doi: 10.1086/452609.
- Rahmzadeh, A, Alam, M.S., and Tremblay, R. 2018. "Analytical Prediction and Finite-Element Simulation of the Lateral Response of Rocking Steel Bridge Piers with Energy-Dissipating Steel Bars." *Journal of Structural Engineering* 144 (11):04018210. doi:10.1061/(ASCE)ST.1943-541X.0002216.
- Tremblay, R., Liu, J., Islam, K., Rahmzadeh, A., and Alam, M.S. 2019. "Seismic Performance of Self-Centering Controlled Rocking Steel Bridge Piers." Proc. 12th Can. Conf. on Earthquake Eng., Quebec City, QC.