



Laval (Greater Montreal)

June 12 - 15, 2019

HORIZONTAL STEEL DESIGN OF REINFORCED CONCRETE RINGWALLS USING SOIL-STRUCTURE INTERACTION

Padros, G.^{1,2}

¹ ARKK Engineering Corp, Sherwood Park AB, Canada

² Gustavo.Padros@arkkeng.ca

Abstract: A procedure is presented to determine the horizontal steel reinforcement of a concrete ringwall embedded in granular fill using soil-structure interaction. The procedure requires the determination of the horizontal stress (hoop stress) that is applied on the ringwall, which depends on the steel strain developed by the ringwall horizontal steel reinforcement and the state of earth pressures acting against the ringwall. The determination of the horizontal displacement of the ringwall allows to estimate the development of active earth pressure against the inside face of the ringwall and passive earth pressure against the outside face of the ringwall. A procedure to determine earth pressures for intermediate cases is also discussed, which requires results from triaxial tests carried out in a soil laboratory. A discussion is included indicating the fallacy of assuming K_0 conditions in the design of ringwalls.

1 INTRODUCTION

Reinforced concrete ringwalls are used as foundations of heavy or tall aboveground tanks when there is doubt whether a foundation will be able to carry the shell load directly, or when shell distortion is a concern, as is often the case in floating-roof tanks, or when local shear bearing capacity requires improvement. Typical advantages of concrete ringwalls include (API Standard 650):

- (a) Provides better distribution of the shell load to produce a nearly uniform load under the tank;
- (b) Provides a flat, solid surface to start installation of the shell;
- (c) Provides a means of leveling the tank grade and it is capable of preserving its contour during construction;
- (d) Retains the fill under the tank bottom and prevents loss of material as a result of erosion; and
- (e) Minimizes moisture under the tank.

The components of a typical concrete ringwall are illustrated on Figure 1. Geometric recommendations from the American of Petroleum Institute (API Standard 650) include a minimum ringwall thickness b of 0.3 m and a maximum vertical distance between the tank bottom and the grade level outside the ringwall y_1 of 0.3 m. The dimensions x , W and y_2 shown in Figure 1 are discussed in Section 5.

The objective of the present paper is: (1) Review the hoop stress equation and the geotechnical parameters involved, (2) Discuss the state of earth pressures acting against concrete ringwall foundations of aboveground tanks, and (3) Propose a methodology based on soil-structure interaction to determine the amount of horizontal steel reinforcement of a concrete ringwall.

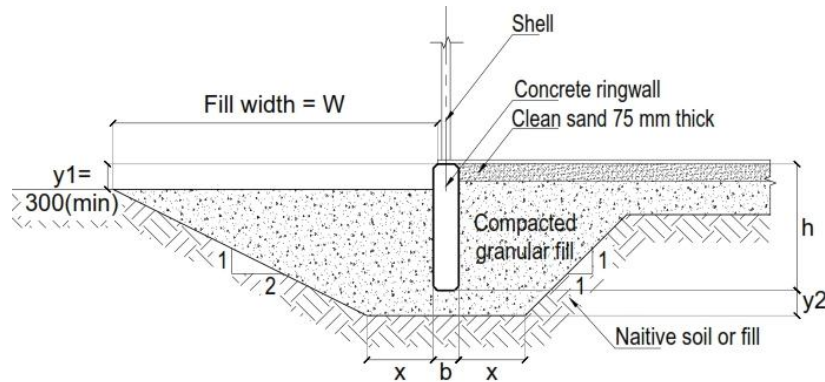

Figure 1. Concrete ringwall embedded in granular fill

2 HOOP STRESS AND HORIZONTAL EXPANSION OF RINGWALL

The horizontal stress σ_h (i.e., hoop stress) acting on a ringwall can be calculated using Equation 1:

$$[1] \sigma_h = R (Ph_{INT} - Ph_{EXT}) / b$$

where R and b are the ringwall radius and thickness, respectively, and Ph_{INT} and Ph_{EXT} are the internal and external horizontal pressures acting on the sides of the ringwall, respectively. A ringwall subjected to hoop stress is illustrated on Figure 2. A cross section of the ringwall showing its geometric configuration and the direction of Ph_{INT} and Ph_{EXT} is shown in Figure 3.

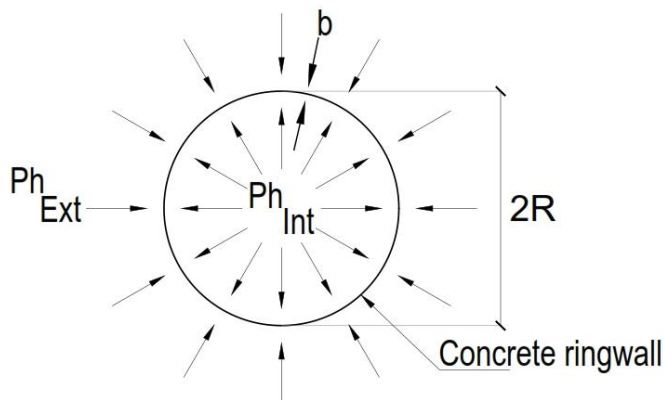

Figure 2. Hoop stress acting on ringwall

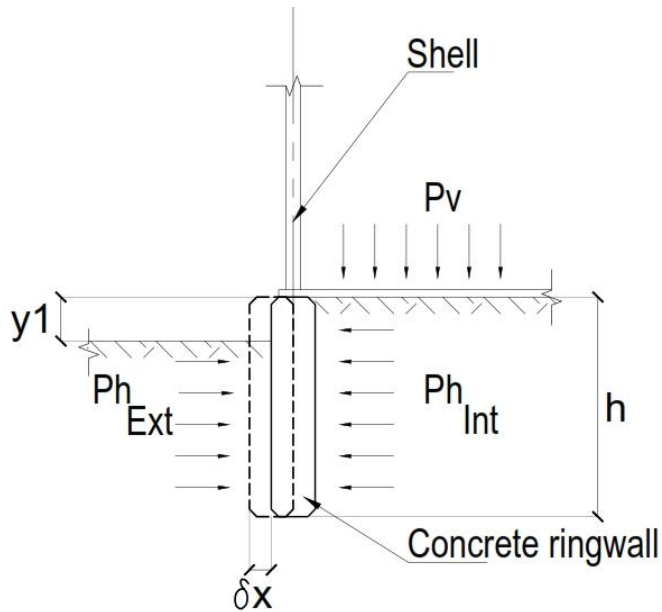

Figure 3. Internal and external pressures against ringwall

The horizontal expansion of the ringwall is caused by the internal horizontal pressure developed by the loaded tank, but it is restrained by the horizontal pressure acting outside the ringwall. The magnitude of these pressures is dependent of the horizontal expansion of the ringwall. Hence it is noted that this is a soil-structure interaction problem.

Once the hoop stress has been determined and neglecting any contribution from concrete to tension, the area of steel A_s is obtained from:

$$[2] 0.85 A_s = \sigma h b(h) / f_s$$

where 0.85 is the resistance factor for reinforcing bars (CSA Standard A23.3-14), h is the height of the ringwall and f_s is the stress acting on the steel rebar, which is a function of the steel strain ϵ_s developed by the rebar, given by:

$$[3] \epsilon_s = f_s / E_s$$

where E_s is the modulus of elasticity of the steel rebar. It may be noticed that the ringwall designer can assign a value of ϵ_s and then determine the area of steel using the equation:

$$[4] A_s = \sigma h b(h) / \epsilon_s E_s$$

The hoop stress produces an expansion on the ringwall and creates a tension force in the horizontal steel reinforcement, causing it to extend. Assuming that the horizontal expansions of the ringwall and steel rebar are equal, then the radius R_E of the expanded ringwall and the horizontal expansion δx of the ringwall are obtained from:

$$[5] R_E = R (1 + \epsilon_s)$$

$$[6] \delta x = R_E - R$$

On this basis, the determination of the horizontal expansion of the ringwall, in combination with an understanding of the mechanical properties and behavior of the fill material placed at both sides of the ringwall, will allow the computation of the hoop stress.

3 INTERNAL AND EXTERNAL EARTH PRESSURES ACTING ON RINGWALLS BACKFILLED WITH GRANULAR SOILS

3.1 Fallacy of Ko Conditions

At-rest earth pressure (K_0) conditions are often assumed when undertaking the structural design of a ringwall, with the expectation that a rigid ringwall will be built, which will confine the fill placed underneath the tank and will prevent horizontal expansions. Consequently, when K_0 conditions are considered, the internal horizontal pressure Ph_{INT} is simply computed as:

$$[7] Ph_{INT} = K_0 (Pv_{INT} + q)$$

where Pv_{INT} is the interior vertical effective stress at the ringwall mid height and q is the maximum liquid pressure that will be applied in the tank foundation, which usually occurs during the hydrotest.

Fill is also placed outside the ringwall, which provides exterior lateral confinement to the ringwall. As mentioned in Section 1 and shown in Figure 1, the vertical distance between the tank bottom and the grade level outside the ringwall is limited to 0.3 m. On this basis, the fill thickness on both sides (exterior and interior) of the ringwall is very similar. Well compacted granular fill placed outside the ringwall provides a certain level of confinement, which in addition to the rigidity of the ringwall makes the tank designer feel confident about the at-rest earth pressure assumption, which is wrong, as discussed below.

The resulting external horizontal pressure Ph_{EXT} is typically determined as:

$$[8] Ph_{EXT} = K_0 (Pv_{EXT})$$

where Pv_{EXT} is the exterior vertical effective stress at the ringwall mid height. For practical purposes it can be assumed that for an unloaded tank, $Pv_{EXT} = Pv_{INT} = Pv$.

Pv_{EXT} is often neglected in the calculations given that $K_0 (Pv)$ is considerably smaller than $K_0 (Pv + q)$. Although this conclusion may appear correct, it is only valid if the at-rest condition was present. However, the resulting earth pressure condition is not at-rest, but a combination of active pressures inside the ringwall and passive earth pressures outside the ringwall. Depending on the amount of horizontal expansion, full active and passive pressures may develop. Furthermore, ringwall expansion is beneficial for tank performance, as it reduces differential horizontal displacements with the shell and as such should be designed for and controlled. In addition, the horizontal steel reinforcement required when ringwall expansion is allowed is smaller, developing a more cost-effective design. The magnitude of Pv_{EXT} is very important in the soil-structure interaction calculations and therefore should not be neglected.

3.2 Internal Earth Pressures

The weight of the liquid inside the tank will compress the fill underneath, which will tend to deform laterally, pushing the ringwall outwards, which will then restrain the horizontal movement of the fill. An active earth pressure condition is hence likely to occur. The ratio of horizontal displacement / ringwall height required to develop a full active earth pressure is relatively small (ranging from 0.001 in dense granular soils to 0.004 in loose granular soils, Fang 1991) and may easily be developed in the fill near the inside face of the ringwall. However, in case of very small ringwall horizontal expansions where the full value of K_a may not be developed, or for ringwalls where the height is large, the granular material selected to serve as fill inside the ringwall should be tested to determine its mechanical properties by means of compression unloading triaxial tests. The tests results will indicate the amount of active pressure developed for a given lateral displacement, as well as the displacement needed to develop the full active earth pressure.

3.3 External Earth Pressures

The soil placed outside the ringwall will be pushed outwards due to the horizontal expansion of the ringwall. Depending on the amount of lateral movement, a passive earth pressure condition may occur on the soil located in the vicinity of the ringwall. The ratio of horizontal displacement / ringwall height required to develop a full passive earth pressure is relatively large (ranging from 0.01 in dense granular soils to 0.04 in loose granular soils, (Fang, 1991)). However, depending on the magnitude of the strain developed in the steel rebar (as can be seen in equations 5 and 6), achievement of passive conditions is not unlikely, particularly for large diameter tanks or when the ringwall height is relatively short. For intermediate cases where the full passive earth pressure condition is not achieved, the actual amount of passive earth pressure developed for a given lateral displacement of the fill material outside the ringwall may be investigated by means of extension loading triaxial tests.

4 PROPOSED SOIL-STRUCTURE INTERACTION METHODOLOGY AND ASSUMPTIONS

The following methodology is proposed to determine the amount of horizontal steel reinforcement for the concrete ringwall:

- (a) Propose a steel strain ε_s developed by the ringwall horizontal steel reinforcement which is compatible with the shell horizontal strain.
- (b) Compute the radius R_E of the expanded ringwall and the horizontal expansion δx of the ringwall using equations 5 and 6.
- (c) Calculate the ratio of horizontal displacement / ringwall height developed and compare it with the values required to develop full active and passive earth pressure conditions (mentioned in Sections 3.2 and 3.3).
- (d) For intermediate cases (not full mobilization of active or passive conditions), undertake tests on the granular fill material to be used and determine its mechanical properties by means of triaxial tests (compression unloading for the fill inside and extension loading for the fill outside the ringwall). Use the results to determine the amount of active or passive earth pressure mobilized.
- (e) Using the full or partial values of the active and passive earth pressures previously determined, compute the values of Ph_{EXT} and Ph_{INT} using equations 9 and 10.

$$[9] Ph_{INT} = Ka (Pv_{INT} + q)$$

$$[10] Ph_{EXT} = Kp (Pv_{EXT})$$

where Ka and Kp are the fully mobilized or partial values of the active and passive earth pressure coefficients, respectively. Other terms were defined in Section 3.

- (f) Apply the results from equations 9 and 10 to compute the hoop stress using equation 1.
- (g) The ringwall horizontal steel area A_s is obtained from equation 4.

The above described methodology is based on the following assumptions:

- (1) The groundwater level is assumed underneath the ringwall.
- (2) Tension resistance of concrete is neglected.
- (3) The friction between the base of the concrete ringwall and the soil underneath is neglected.
- (4) The horizontal expansion of the ringwall and the shell are considered equal.

5 PROPOSED SOIL-STRUCTURE INTERACTION METHODOLOGY AND ASSUMPTIONS

In order to illustrate the discussion and methodology included hereto, an example of soil-structure interaction for a 40 m diameter tank will be presented. Limit states will be considered, applying a load factor of 1.5 and a geotechnical resistance factor of 0.5 to the active and passive earth pressures, respectively. The data is presented in Table 1.

Table 1: Data for soil-structure interaction example

Component	Parameter	Value
Soil	Unit weight	20 kN/m ³
	Angle of internal friction	36 deg
Concrete ringwall	Diameter	40 m
	Height	1.5 m
	Width	0.3 m
	y ₁	0.3 m
	y ₂	0.3 m
	x	1.5 m
	W	3.9 m
	Horizontal steel strain ϵ_s	0.001
Shell	Horizontal strain ϵ_s at the bottom of the shell	0.001
ULS load	Hydrotest load	300 kPa

The tank designer indicated that the calculated horizontal strain at the bottom of the shell was $\epsilon_s = 0.001$, which would occur at the time of the tank hydrotest, when a ULS factored vertical load $q = 300$ kPa was applied at the bottom of the shell. On this basis, in order to minimize differential horizontal displacements between the bottom of the shell and the ringwall, the horizontal strain of the steel rebar was selected as $\epsilon_s = 0.001$.

The results of the calculations are included in Table 2. Based on the horizontal displacement computed, active earth pressures were considered for the granular fill inside the ringwall. In order to determine the amount of passive earth pressure developed, the mechanical properties of the granular fill were investigated by means of an extension loading triaxial test. The results of the test are presented in Figure 4 and summarized in Tables 1 and 2.

Dimensions x and W indicated in Table 1 are illustrated in Figure 1 and correspond to the area of the granular fill located outside the ringwall. These dimensions are used to verify that the wedge of soil subjected to passive pressure fits in the area enclosed between x , W and h . Furthermore, should the weight of the wall be greater than the friction between the sand and the wall, then the shape of the wedge subjected to passive earth pressure will develop a concave curvature extending from the bottom of the ringwall downwards, subsequently rising towards the ground surface (logarithmic spiral). The dimension y_2 is used for this case, to make sure that the passive wedge will fit inside the granular fill cross section.

It is interesting to note that if K_0 conditions had been considered, the hoop stress computed would have been 8,700 kPa. At that moment the designer would have to choose the horizontal strain of the steel rebar. If the same value as the shell horizontal strain ($\epsilon_s = 0.001$) is selected, then the steel rebar area would be 22,375 mm², corresponding to 2.1 times more steel area than was computed using the methodology discussed here.

The proposed methodology allows a more cost-effective design, particularly important when considering the amount of horizontal steel a large diameter tank requires. It is also important to note that if K_0 conditions had been considered and the above noted steel rebar area was used, then the horizontal displacements in the shell and ringwall upon tank loading would be different, resulting in differential horizontal displacements between these elements.

Table 2: Results of soil-structure interaction example

Parameter	Result	Comment
R_E	20.02 m	Expanded ringwall radius
δx	0.02 m	Horizontal expansion of the ringwall
$\delta x / h$	0.013	Sufficient for K_a but requires K_p assessment (lab tests)
K_a	0.260	Full value of K_a
ULS $P_{V_{INT}}$	323 kPa	ULS factor = 1.5
ULS $P_{H_{INT}}$	84 kPa	ULS factor = 1.5
$\epsilon_x = \delta x / h$	0.013	Assumed equal to soil horizontal strain
σ_1' / σ_3'	3.75	From Figure 4
$\Phi_{P_{V_{EXT}}}$	6 kPa	$\Phi = 0.5$
$\Phi_{P_{H_{EXT}}}$	22.5 kPa	$\Phi = 0.5$
σ_h	4,105 kPa	Hoop stress
A_s	10,555 mm ²	Final result

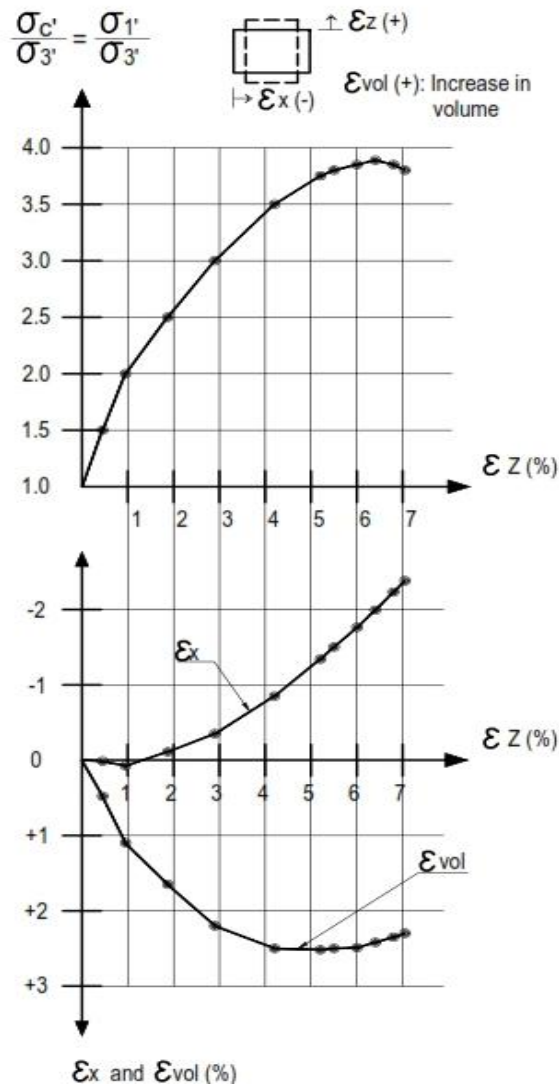

Figure 4. Results of extension loading triaxial test

6 CONCLUSIONS

1. A steel tank superstructure (i.e., shell) will expand horizontally as a result of loading. The reinforced concrete ringwall should be designed to have the same expansion as the shell to prevent differential horizontal displacements between the tank superstructure and its foundation.
2. The at-rest earth pressure condition, which is often assumed when a reinforced concrete ringwall is designed, is only valid if the steel strain $\epsilon_s = 0$. This would only be true for an unloaded tank or for an extremely rigid, heavily reinforced ringwall. Under any other condition, a reinforced concrete ringwall subjected to hoop stress will expand.
3. In order to decrease differential horizontal displacements between the shell and the ringwall, the value of ϵ_s used in the soil-structure interaction to determine the amount of horizontal steel reinforcement of the ringwall should be equal to the ϵ_s developed by the shell near its connection to the foundation, which should be obtained from the structural designer of the tank.
4. Once the ϵ_s has been established, the earth pressures acting on the interior and exterior sides of the ringwall may be found through soil-structure interaction. The earth pressure acting on the interior will correspond to the active state, which will require a relatively small horizontal displacement of the ringwall to be mobilized, whereas the earth pressure acting on the exterior will correspond to the passive state, which although will require larger horizontal displacements to be fully mobilized, may provide important confinement even if not fully developed.
5. Well compacted fill outside the ringwall, displaced horizontally due to the lateral expansion of the ringwall, may develop relatively large horizontal earth pressures, which could even reach the full value of passive earth pressures. On this basis $P_{V_{EXT}}$ should not be neglected in the calculations as its magnitude influences the results obtained in the soil-structure interaction.
6. The soil-structure interaction presented in Sections 4 and 5 is a simple procedure that allows the determination of the horizontal steel reinforcement by calculating the hoop stress acting on the ringwall. The horizontal pressures (internal and external) acting against the ringwall are obtained from the mechanical properties of the granular fill, determined through soil laboratory triaxial tests comprising extension loading (for the passive earth pressure) and compression unloading (if necessary, for the active earth pressure).

REFERENCES

- American Petroleum Institute, 2014. Welded Tanks for Oil Storage, API Standard 650. Addendum 1. Washington D.C.
- Canadian Standard Association, 2014. *CSA Standard A23.3-14. Design of Concrete Structures*. Ottawa, ON, Canada.
- Canadian Geotechnical Society, 2006. *Canadian Foundation Engineering Manual*. 3rd Edition, Vancouver, BC, Canada.
- Fang, H. Y. (Editor). 1991. *Foundation Engineering Handbook*. 2nd Edition. Chapter 6, Earth Pressures. Van Nostrand Reinhold. New York, NY, USA.
- Padros, G. 2018. Soil-Structure Interaction of Reinforced Concrete Ringwalls in Granular Fill. Canadian Geotechnical Conference, Edmonton, AB, Canada.
- Taylor, D.W. 1948. *Fundamentals of Soil Mechanics*. John Wiley. New York, NY, USA.
- Terzaghi, K. and Peck, R. 1967. *Soil Mechanics in Engineering Practice*. 2nd ed., John Wiley. New York, NY, USA.