



RESILIENCE ASSESSMENT OF WATER NETWORKS AGAINST SEISMIC HAZARD

Assad, Ahmed^{1,4}, Nasiri, Fuzhan², and Zayed, Tarek³

¹ Ph.D. Student, Concordia University, Canada

² Assistant Professor, Concordia University, Canada

³ Professor, Hong Kong Polytechnic University, Hong Kong

⁴ ahmed.assad@mail.concordia.ca

Abstract: Water Supply Networks (WSNs) are critical infrastructure systems that provide water to the public. Maintaining functionality of WSNs is desirable especially after hazard events to facilitate firefighting and rescue activities. Aging of WSNs increases their vulnerability and the likelihood of function interruption. There is a growing need to investigate the resilience of infrastructure systems to assess their ability to withstand a disruption and to recover rapidly after service interruption. Several models have been developed to consider resilience during the design of WSNs, however there is a setback regarding incorporation of resilience in repair strategies. This study introduces a resilience-based approach that aims at both evaluating the resilience of WSNs as well as enhancing their recoverability after a hazard event. Firstly, a resilience metric is suggested based on the physical condition of the pipelines in the WSN. Secondly, causal loop diagrams are established to capture the interactions among the parameters related to asset condition, hazard intensity, performance loss, rehabilitation and restoring activities. Thirdly, stock and flow diagrams are generated, relevant mathematical and logical relations between the parameters are defined, and several checks are performed to verify the developed model. Finally, the model is applied on a portion of Montreal WSN to simulate an earthquake that causes around 40% performance loss. A budget of 750,000 dollar is found sufficient to recover the network resilience to 75% of its initial value. The practical value of this study is signified by the tool, which can be used by the stakeholders to select the best management and mitigation strategies that increases the resilience absorptive and restorative capacities of their WSNs.

1 INTRODUCTION

Following any hazard, water infrastructures play a dominant role in firefighting and rescue efforts. Hence, maintaining the functionality of such critical systems is of a paramount importance after any hazard event or disruption (Farahmandfar et al. 2016). While the traditional focus was on the physical protection of water systems, the emerging trend is highly raising the issue of resilience. The American Society of Civil Engineers defines the resilience of infrastructure as the ability to mitigate all-hazard risks and rapidly recover critical services with minimum harm to the public safety, health, economy and national security (Ayyub 2014). In this context, it is desirable for the water networks to be strong enough to withstand any disruption with a minimum impact on its performance and to recover quickly in case of service loss (Cimellaro et al. 2015). Consequently, there has been a rapidly increasing attention both, in practice and academia, to define resilience and derive quantifiable resilience metrics. The literature includes several frameworks that have been developed to include during the design and operation of civil infrastructures. Nevertheless, most of the previous work focused on a single hazard event instead of assessing the

resilience of water assets to multi-hazard events. Moreover, there are very limited efforts that consider the various aspects and parameters of WNs resilience. Therefore, this paper introduces a comprehensive resilience assessment framework and demonstrates its use in evaluating resilience of water networks as well as selecting optimal recovery strategies.

1.1 Background

Reviewing the literature reveals two main approaches for measuring and assessing resilience of water networks: qualitative approaches and quantitative approaches. Most of the qualitative approaches comprise listing resilience attributes, assigning them numerical weights, and then aggregating these weighted metrics into a single composite index. The main drawback of this approach is ignoring the relations between the indicators. Fisher et al. (2010) introduced a resilience index to measure the resilience of critical infrastructures including water systems. The model required extensive data collection about 1,500 variables categorized under robustness, recovery, and resourcefulness. The variables were then weighted and summed to generate a single global resilience index that facilitates the comparison between different infrastructure systems (Fisher et al. 2010). Such approaches are usually subjective, and the results cannot be generalized on a large scale. Quantitative approaches of resilience assessing involve modeling the impact of a specific hazard on the network. Such approaches account for two main components of resilience: the hazard severity and the system response. Some studies employed resilience as a system property and aimed to investigate the dynamic relations between the components of the system. Jayaram and Srinivasan (2008) formulated a resilience assessment model that accounts for multiple sources within a network, a major limitation of Todini's model (Jayaram and Srinivasan 2008). Gay and Sinha (2013) integrated MATLAB and EPANET2 software packages to develop a stochastic simulation-based methodology to assess the resilience of water distribution system. Simulations were run to quantify the performance loss, recovery time and recovery cost following a hazard event (Gay and Sinha 2013). Another quantitative approach to evaluate system's resilience employs it as the opposite of the system's vulnerability to various disruptions. Principles of graph theory were utilized in many of these approaches to model the water network as nodes and links (Farahmandfar et al. 2016). Despite the previous efforts in trying to address the performance assessment of water networks, several drawbacks can be realized. Most of the proposed models aimed at enhancing the resilience with the minimum cost. Such approach overlooks other chief objectives that should be considered such as time of service disruption. Moreover, very few models addressed the issue of repair and recovery actions considering the scarcity of non-monetary resources. Accordingly, this study is utilizing system dynamics simulation to introduce a scenario-based approach for assessing the resilience of water networks. This approach is intended to provide a deeper insight on the inter-relations between the different system parameters, hazard characteristics, and recovery strategies. To achieve the ultimate aim of this study the below objectives needs to be satisfied:

- Identify causal relationships between the parameters of water network resilience.
- Construct stock and flow diagrams based on the developed causal relationships.
- Simulate a hazard scenario and investigate the effect of different restoration strategies on the time of service disruptions.

2 DATA COLLECTION

The City of Montreal granted an access to their data base of water distribution network. The city of Montreal is responsible for managing a huge inventory of water pipeline some of them was installed as far back as 1895 and is still active till today. Figure 1 shows that over 92% of the City's network is either cast iron or ductile iron. The extracted data include data related to the characteristics of the pipeline, installation data, and breakage data. The breakage data include the number and time of each observed break in the network.

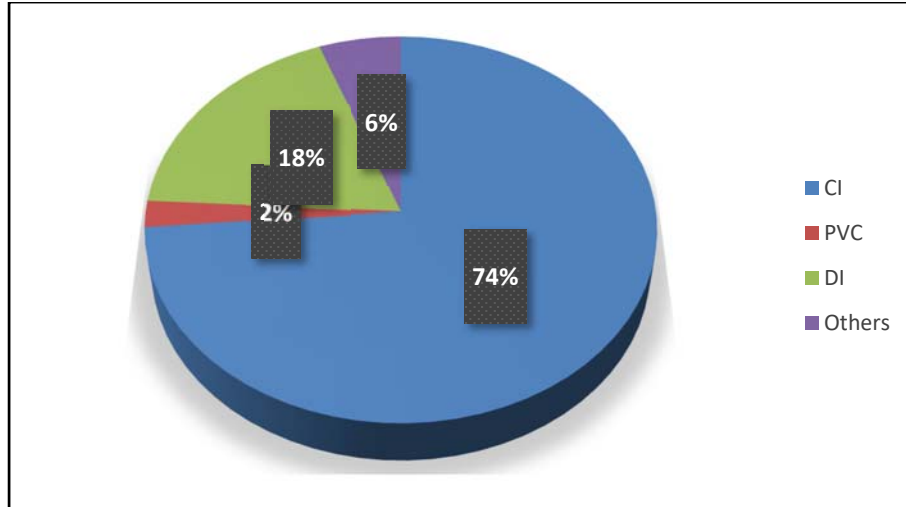

Figure 1 : Distribution of Pipe size

The breakage rate along with the pipe age were used as indications of the pipe's condition. In this study, three condition ratings are considered namely: Excellent Condition, Good Condition, and Poor Condition. Each of these conditions is mapped to a certain resilience state such that an excellent condition corresponds to withstanding resilient, good condition to resilient, and poor condition to non-resilient.

3 MODEL DEVELOPMENT

A literature review was done to investigate the different available models on resilience of WSNs. afterwards, the needed factors to develop a causal loop diagram were identified. Based on this diagram, stock and flow diagrams were generated and the associated logical and mathematical relations were defined. Figure 2 is the causal loop diagram that serves as the basic rationale of this study. The main parameters in this diagram are hazard characteristics and its impact on resilience state as well as the factors controlling the restoring activities along with their impact on the resilience state. There is a reinforcing, positive, relationship between the hazard intensity and the performance loss it causes to the system. More over, the exhibited loss is less when the absorptive capacity of this asset is higher. The second loop in this diagram is capturing the ownership policies and the owner willingness to pay. As the asset is in a better resilience state, the owner will be less likely to spend on it. Hence a lower budget will be allocated for this particular asset, less bargaining power. However, with a continuous decrease in the possible repair activities the overall resilience estate will deteriorate. Figure 3 illustrates the stock and flow diagram which is generate based on the aforementioned causal loop diagram. In this diagram, there main stock variables were defined namely: withstanding resilient, resilient and non-resilient. Each stock represents the number of water mains in a certain resilience state. An asset would typically flow from one resilience state to a lower one causing a performance loss due to the hazard event occurrence. In this model, two attributers are used to quantify the hazard characteristics: the severity of the hazard and its duration. On the other hand, the restoring activities will cause an asset to flow on the opposite direction, from a lower to a higher resilience state. The parameters that control these resorting activities are related to the share of the budget allocated for each repair type as well as the resource availability ratio. The earlier one is usually set a head of time during the evaluating of losses and planning phase while the latter is a property that describes the entity's ability to address more than one repair task at once. This ability is generally a function of the entity's manpower, machinery, and available money. It should be noted that for further clarity, some intermediate variables are hidden. Figure 4 shows the remaining parameters of the model and it includes the life cycle costing, budget allocation and network resilience computations. The overall network resilience can be found using equation 1:

$$[1] \text{ Network Resilience} = \frac{3 \times \text{Withstanding Resilient} + 2 \times \text{Resilient} + 1 \times \text{Non-Resilient}}{\text{Withstanding Resilient} + \text{Resilient} + \text{Non-Resilient}}$$

Where: withstanding resilient is the number of assets that are in a withstanding resilience state, resilience is the number of assets that are in a resilient state, and non-resilient is the number of assets that are in a non-resilient state.

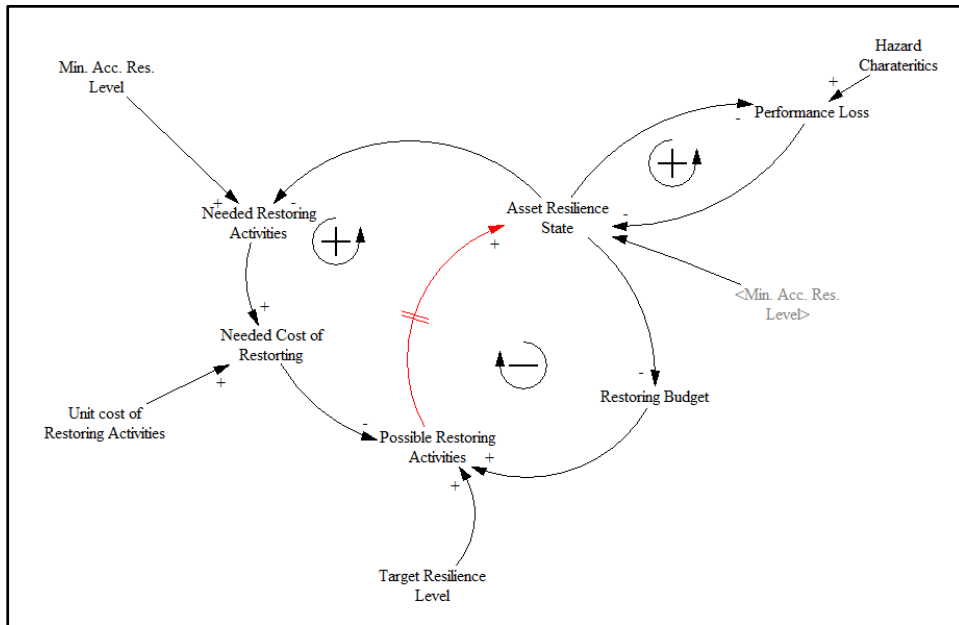

Figure 2 Causal loop diagram

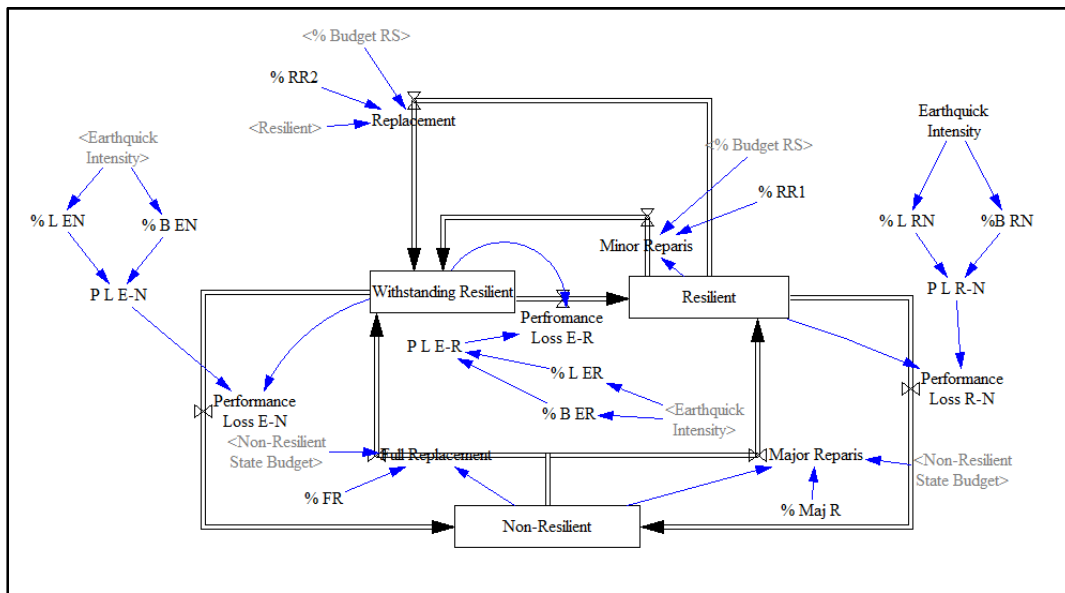
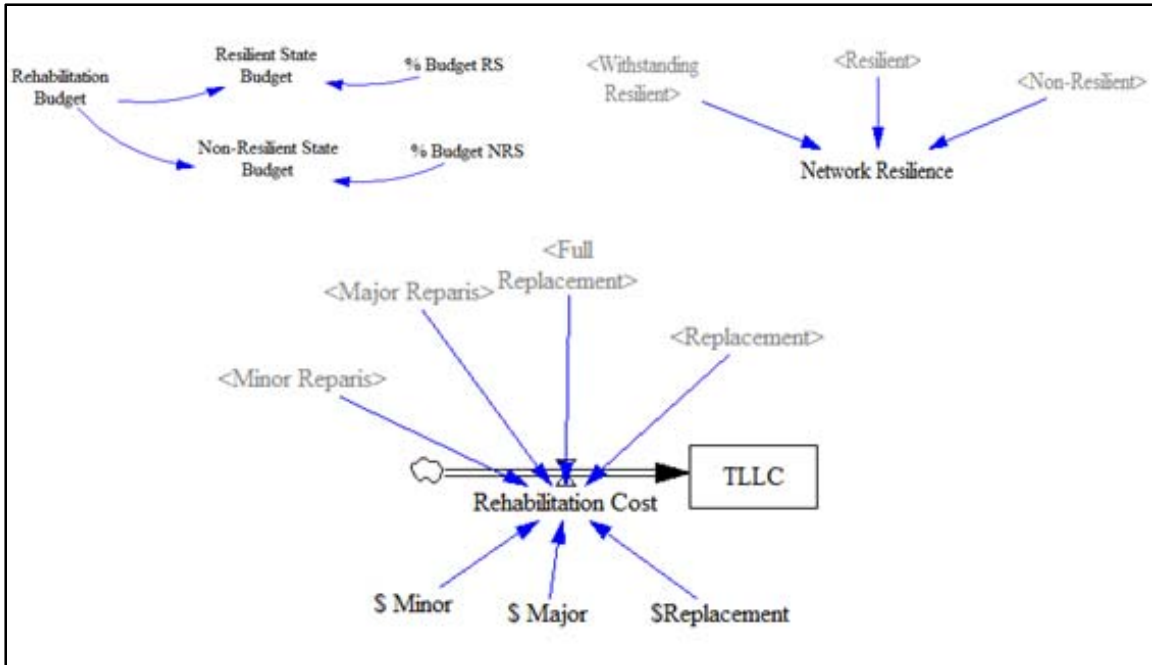

Figure 3 Stock and flow diagram (technical)



4

Figure 4 Stock and flow diagram (financial)

In Figure 4, the stock variables are calculated as the difference between the inflows and outflows at any time instant. For example, the withstanding resilient stock which represents the number of assets in a withstanding resilient state is computed using equation 2:

$$[2] \text{ Withstanding Resilient} = \int \text{full replacment} + \text{minor repairs} - \text{perfromance loss}_{E-N} - \text{perfromance loss}_{E-R}$$

Where full replacement represents the number of pipe assets that are fully replaced with new ones, major repairs represent the number of assets that experience a major repair, performance loss_{E-N} and performance loss_{E-R} represents the number of assets that deteriorates from withstanding resilience to non-resilience or from withstanding resilience to resilience states respectively. The number of water mains that will experience a minor repair, major repair, or full replacement is determined based on the pre-set budget allocated for each restoring type. The number of assets that the performance loss that identifies the number of assets deteriorating from one state to another in correlated to the hazard intensity.

5 RESULTS AND DISCUSSIONS

A preliminary test of the model was performed on a virtual water distribution network that consists of 115 pipelines. The condition of the assets was forecasted and mapped to the corresponding resilience state. Twenty-five pipelines were classified in withstanding resilience state, seventy as were classified as resilient, and twenty were classified as in the non-resilient state. An earthquake is simulated as the hazard event of this model. The probability that the Liquification Potential Index exceeding a threshold of five, P(LPI>5) is the basis of estimating its intensity in this study (American lifeline Alliance, 2005). The assumed earthquake has P(LPI>5) between (45%-95%). Subsequently, performance loss indices were assumed based on the hazard intensity. These assumptions can be changed based on the operational and environmental condition of the network as well as its topology and location. Any variance in assigning the values of these parameters can be readily handled by sensitivity analysis. In this study, three repair (resorting) activities are included: minor, major and full replacement. It is assumed that a minor repair would transfer an asset from resilient to withstanding resilient stare, a major activity would transfer an asset from non-resilient to a resilient state, and a full replacement would transfer an asset from non-resilient to withstanding resilient state. Figure 5 depicts the variation of the three stock variables over time because of both the performance losses and the

resorting actives. The network resilience dropped initially from 2.04 – 1.27 due to the earthquake. It was recovered to a value of 1.47 in a period of two months. It can be noticed from figure 5 an increase in the value of non-resilient state compared to a drop in the resilient and withstanding resilient states at the beginning of the simulation. That is due to the fact that the hazard event causing the witnessed performance loss started at that instant. On the other hand, the graph shows an increase in the values of the resilient and withstanding resilient states upon the end of the simulation period affected by the accumulated restoring activities that were achieved. Figure 6 shows that the allocated budget for the recovery in this scenario is 750,000, however the total encountered cost is just around 513,000. This is because of the hidden delays that are implemented in this model. Such delays are known as performance delays which reflect the real time spent between initiating the repair action and achieving it. various scenarios were then simulated to investigate the effect of changing the total budget on the overall network resilience. The effect of changing the budget on the overall network resilience at the end of the recovery process is shown in Figure 7. It was possible to increase the network resilience to a value of 1.60 at the end of the second month by increasing the resorting budget to 1.5million dollar.

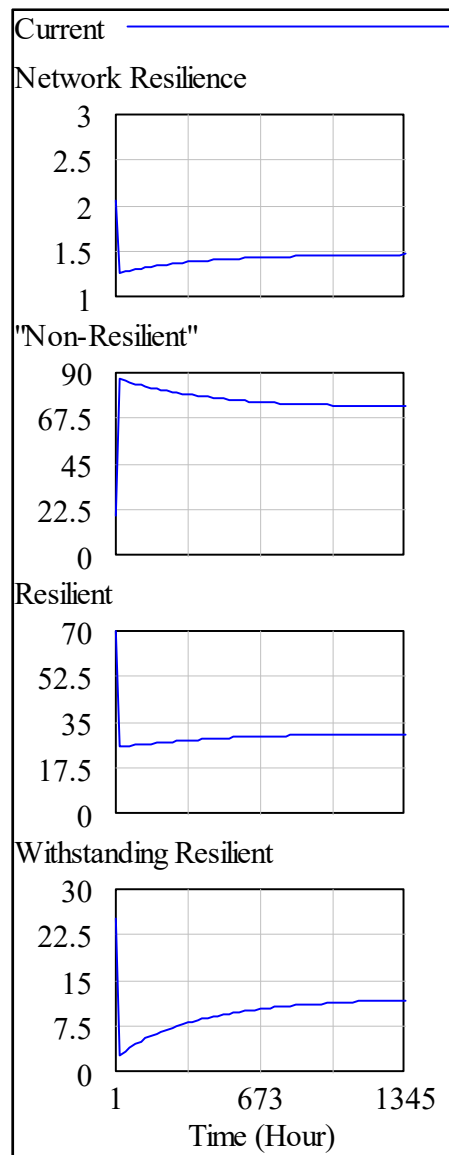

Figure 5 Variation of stock variables

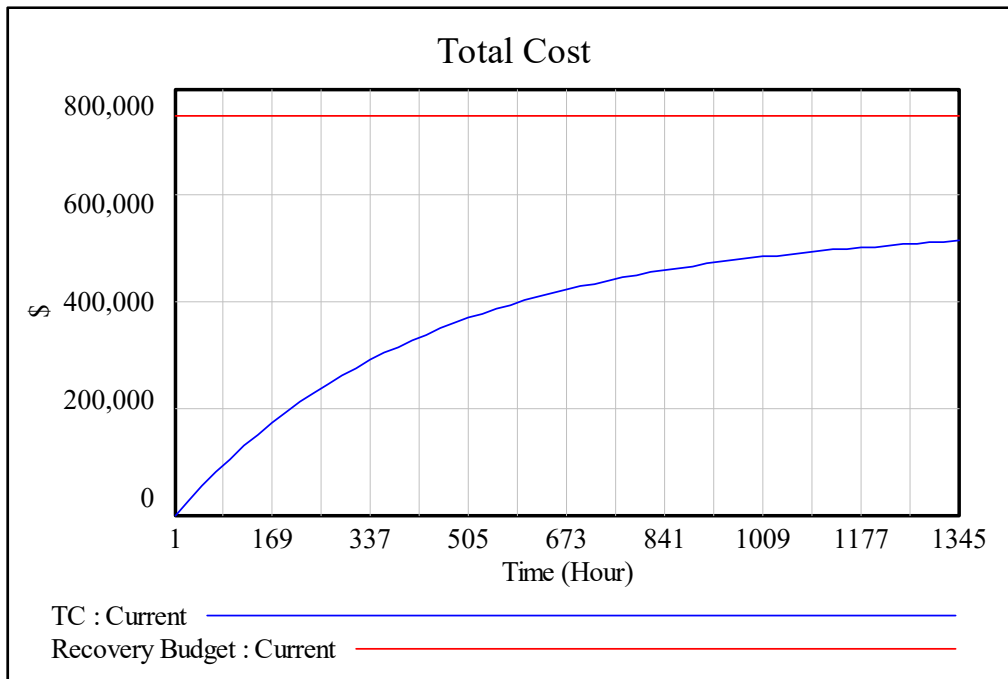

Figure 6 Total accumulated cost

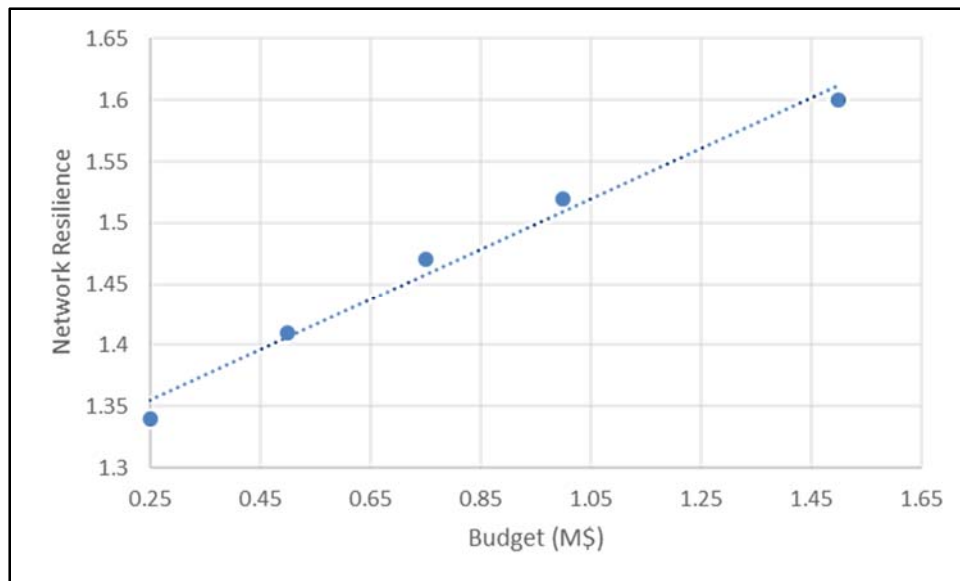

Figure 7 Effect of changing the budget on overall network condition

6 CONCLUSION

A novel resilience assessment model is presented in this study. The model utilizes the use of system dynamics simulation to establish a scenario-based resilience assessment for water network to multi-hazard events. This paper demonstrates the feasibility of using system dynamic as a way to capture all the different aspects of resilience including the system attributes, the hazard characteristics, and the resorting polices

and procedures. Different scenarios might be investigated in future work based on the formulation of this model. Examining the effect of different budget allocation strategies, different hazard intensities, and different on the overall resilience process are just examples.

References

- ALA (American Lifelines Alliance). (2005). Seismic guidelines for water pipelines. (http://www.americanlifelinesalliance.com/pdf/SeismicGuidelines_WaterPipelines_P1.pdf) (Jan. 29, 2017).
- Ayyub, B. M. (2014). Systems resilience for multihazard environments: Definition, metrics, and valuation for decision making. *Risk Analysis*, **34**(2), 340–355.
- Cimellaro, G. P., Tinebra, A., Renschler, C., and Fragiadakis, M. (2015). New Resilience Index for Urban Water Distribution Networks. *Journal of Structural Engineering*, **142**(8), C4015014.
- Farahmandfar, Z., Piratla, K. R., and Andrus, R. D. (2016). Resilience Evaluation of Water Supply Networks against Seismic Hazards. *Journal of Pipeline Systems Engineering and Practice*, **8**(1), 4016014.
- Fisher RE et al. (2010) Constructing a Resilience Index for the Enhanced Critical Infrastructure Recovery Program. Lemont, IL: Argonne National Laboratory. ANL/DIS-10-9.
- Gay, L. F., and Sinha, S. K. (2013). Resilience of civil infrastructure systems: Literature review for improved asset management. *International Journal of Critical Infrastructures*, **9**(4), 330–350.
- Jayaram, N., and Srinivasan, K. (2008). Performance-based optimal design and rehabilitation of water distribution networks using life cycle costing. *Water Resour. Res.*, **44**(1), W01417.